

FITNESS360[®]

FT3346

Smith til Rack



SAFETY PRECAUTION

Before using your equipment, please take a few moments to read these safety instructions carefully. Following these guidelines will help reduce the risk of injury and ensure safe, long-lasting use of your equipment.

a. Assembly

- Assemble the equipment according to the instructions provided.
- Only use the supplied parts intended specifically for this product.
- Before assembly, check that all components listed in the parts list are included

b. Read the Manual

- Read and understand this Owner's Manual before using the equipment.
- Familiarize yourself with all warning labels and recommended operating procedures.
- If you are unsure about proper use, consult your retailer or a qualified fitness professional.

c. Keep Documentation and Labels Intact

Retain this Owner's Manual for future reference and ensure all warning labels remain legible and intact. Replacement manuals and labels are available from your retailer.

d. Assistance During Assembly

- We recommend that two people assemble this equipment.

e. Consult a Physician

Consult your physician before beginning any exercise program, particularly if you have any medical conditions or concerns.

f. Children and Safety

Never allow children to use or play around the equipment without adult supervision.

g. Inspect Cables Regularly

- Regularly inspect cables for signs of wear or damage.
- Do not use the equipment if any cable is frayed or damaged.

h. Keep Clear of Moving Parts

Keep hands, limbs, loose clothing, jewelry, and long hair away from moving parts.

i. Use Appropriate Weight Loads

Do not attempt to lift more weight than you can safely control.

j. Exercise Responsibly

Train within your recommended fitness level. Do not exercise to exhaustion. Stop immediately if you experience pain, dizziness, or discomfort.

k. Inspect Equipment Before Use

Check the machine regularly for loose hardware, worn parts, cracks, or other damage. Do not use the equipment until defective parts have been repaired or replaced.

l. Keep Sharp Objects Away

Do not place sharp objects around or near the machine.

m. Maximum User Weight

Maximum user weight: 120 kg.

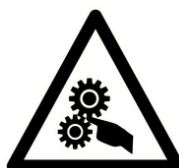

ASSEMBLY INSTRUCTION

I. Assembly Notes

Before assembling your equipment, please read these instructions carefully.

- Ensure you have sufficient space to safely assemble and operate the machine.
- To protect your flooring, place cardboard or another protective material beneath the equipment during assembly.
- The supplied nuts and bolts are lightly coated with grease to help prevent corrosion. Keep a cloth nearby to wipe your hands if necessary.
- Plastic end caps and plugs are pre-installed before shipment. They are shown in the assembly drawings for reference should replacement parts be required.
- The equipment uses bolts of different lengths. Always ensure you use the correct bolt specified for each assembly step.
- If drilling into walls or floors is required, ensure there are no concealed electrical cables, water pipes, or other utilities in the drilling area.

II. Before You Begin

- Choose a spacious, well-lit, and well-ventilated area for assembly.
- We recommend assembling the equipment with the assistance of another person, as some components may be heavy or difficult to handle.
- Ensure there is adequate clearance around the equipment for both assembly and safe operation.













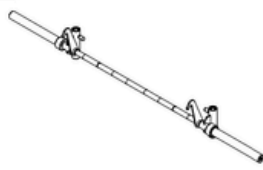

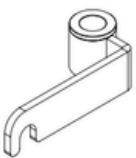
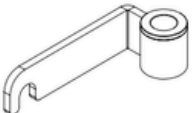
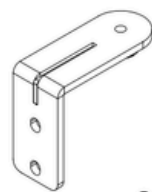
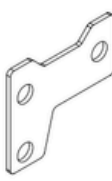
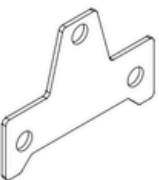

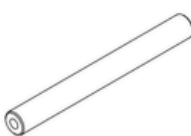
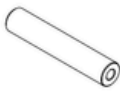

Tools Required

- Standard screwdriver
- WD40 lubricant or Vaseline (if necessary)

III. Assembling Your Machine



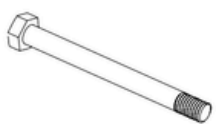

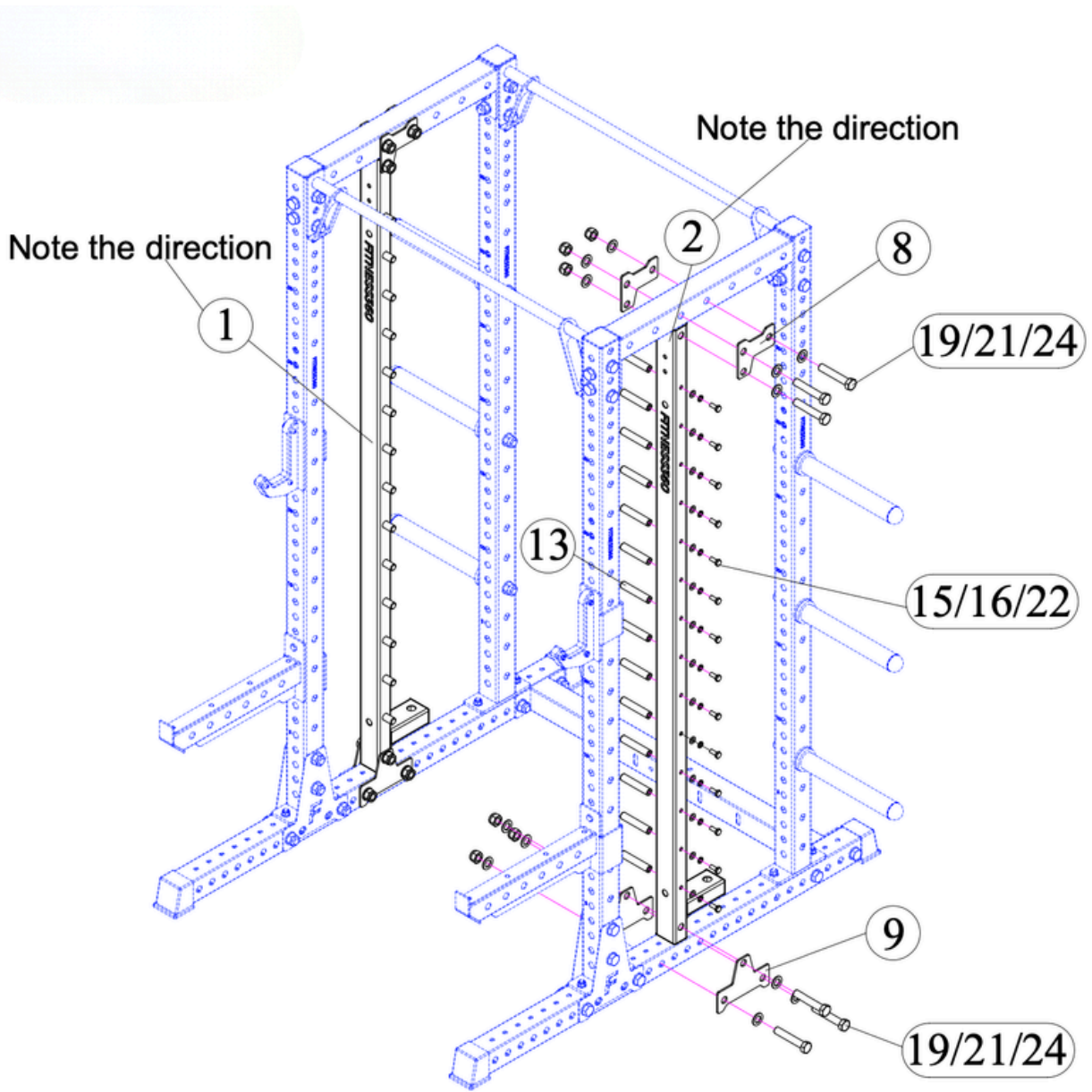

Follow the step-by-step assembly instructions on the following pages. Ensure all bolts are securely tightened before using the equipment.

PART LIST

1  1 PC	2  1 PC	3  1 PC	4  2 PC
5  1 PC	6  1 PC	7  2 PC	8  4 PC
9  4 PC	10  2 PC	11  4 PC	12  4 PC
13  28 PC	14  2 PC	15 M10 Washer  30 PC	16 M10 Spring washer  36 PC
17 M10 BIG Washer  8 PC	18 M12 Washer  8 PC	19 M20 Washer  24 PC	20 M12 Nut  4 PC
21 M20 Nut  12 PC	22 M10*25 Bolt  38 PC	23 M12*75 Bolt  4 PC	24 M20*110 Bolt  12 PC

STEP 1







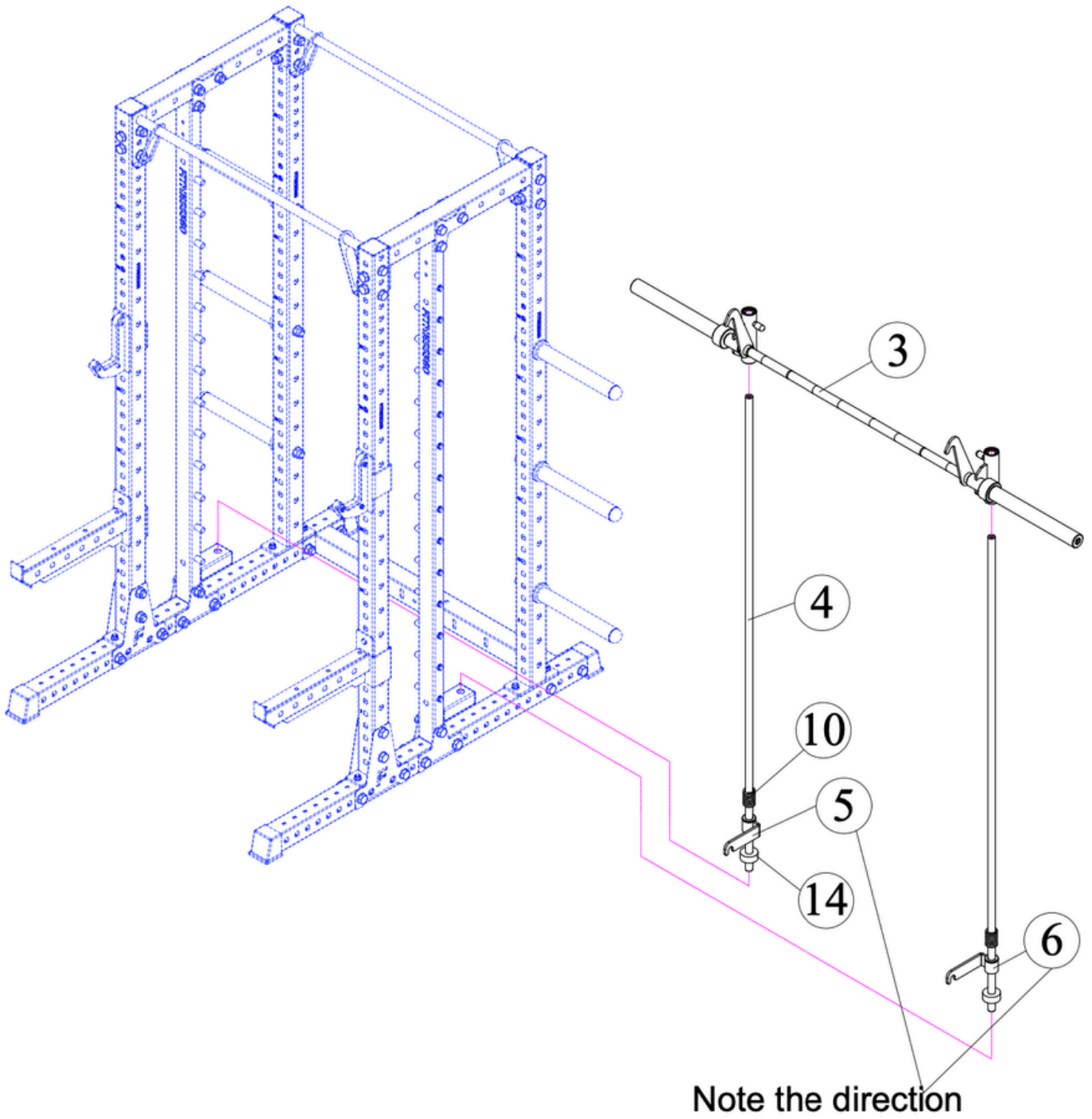

22#		M10*25	Qty:28
24#		M20*110	Qty:12
15#		10	Qty:28
16#		Spring 10	Qty:28
19#		20	Qty:24
21#		M20	Qty:12

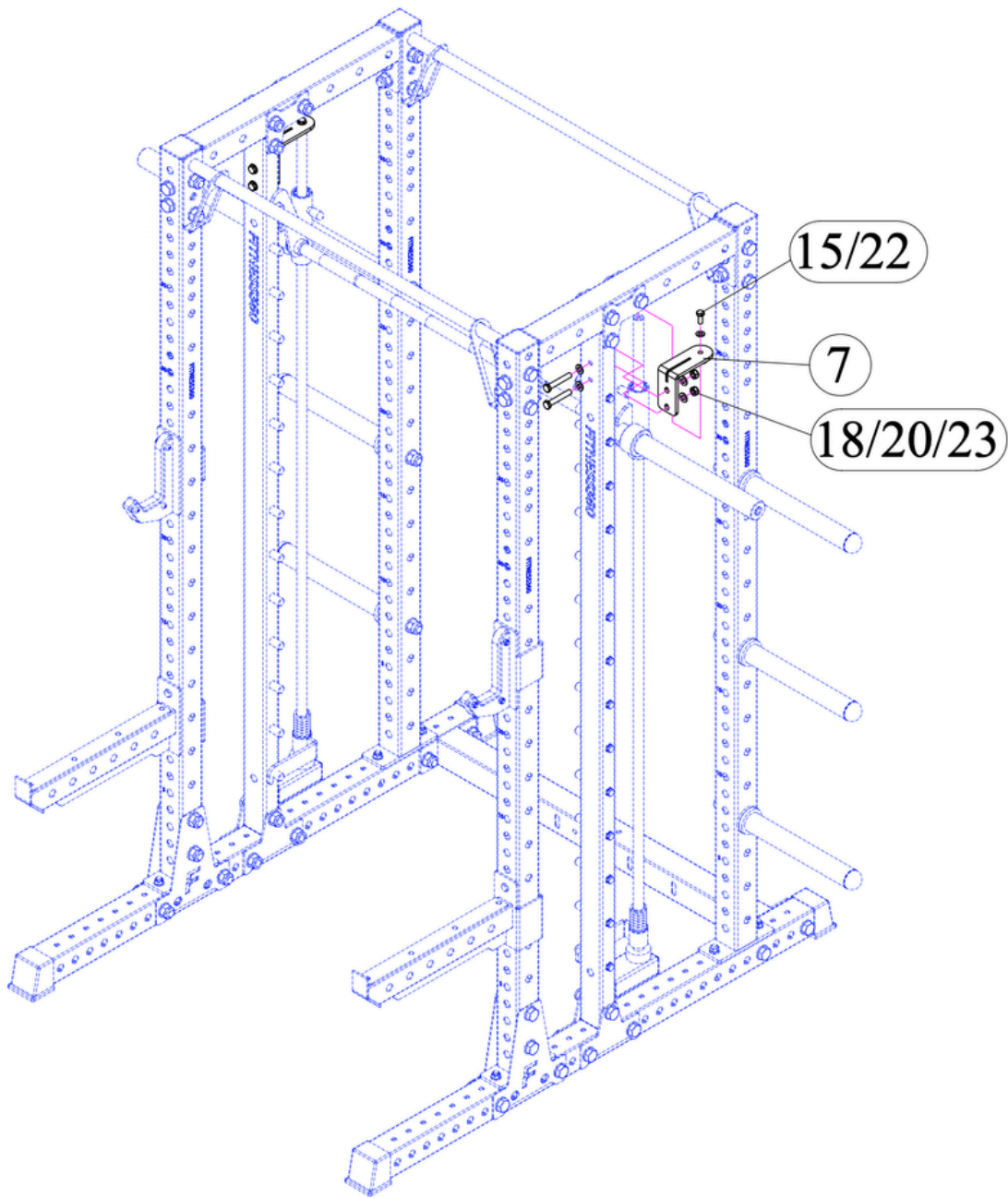
STEP 2



STEP 3



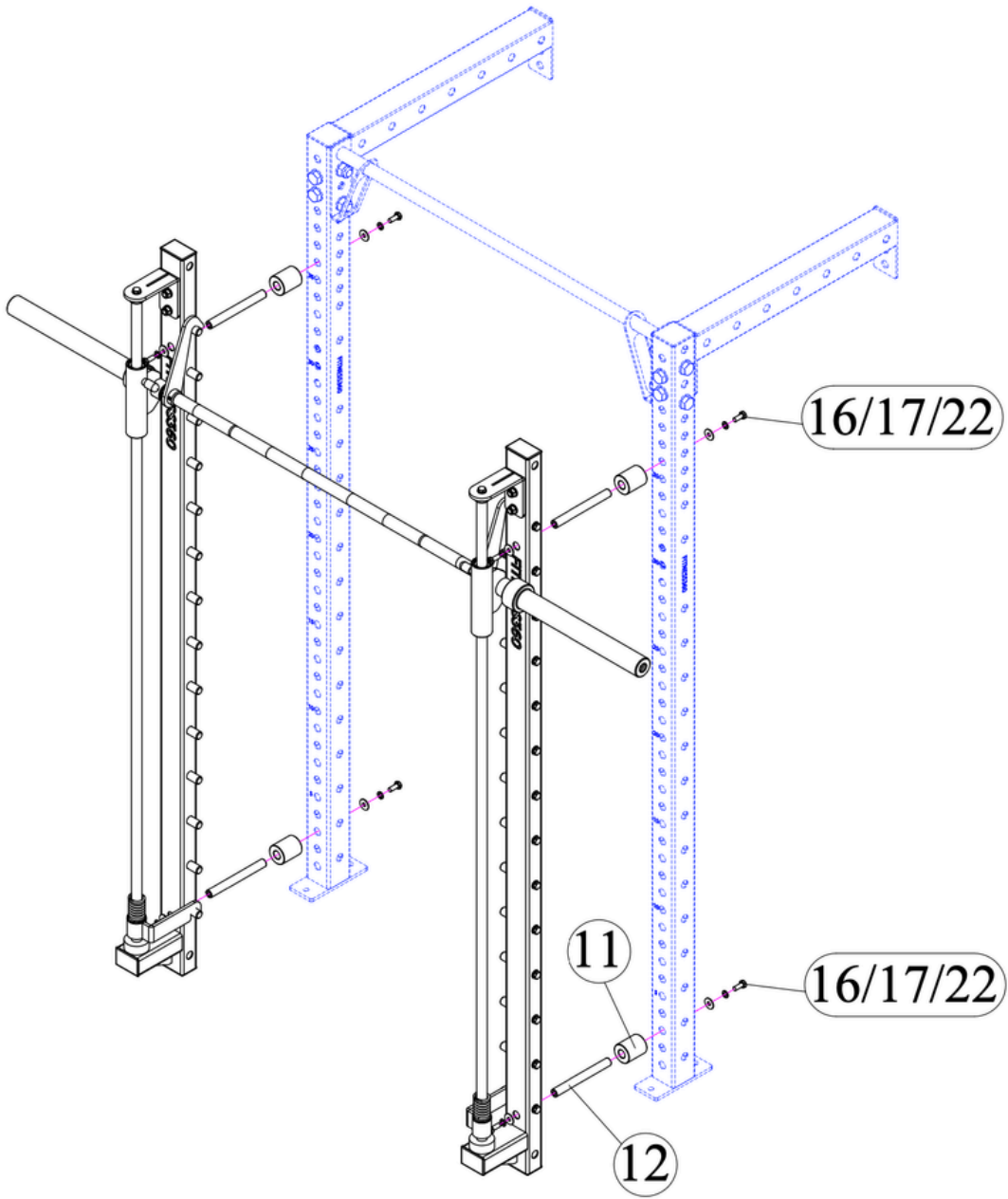

22#		M10*25	Qty:2	15#		10	Qty:2
23#		M12*75	Qty:4	18#		12	Qty:8
				20#		M12	Qty:4

STEP 4



22#		M10*25	Qty:8
-----	---	--------	-------

16#		Spring 10	Qty:8
17#		BIG 12	Qty:8